



fabricant

# HACHOIR RÉFRIGÉRÉ DRC VR82

## REFRIGERATED MINCER DRC VR82

Fiche technique / Technical sheet

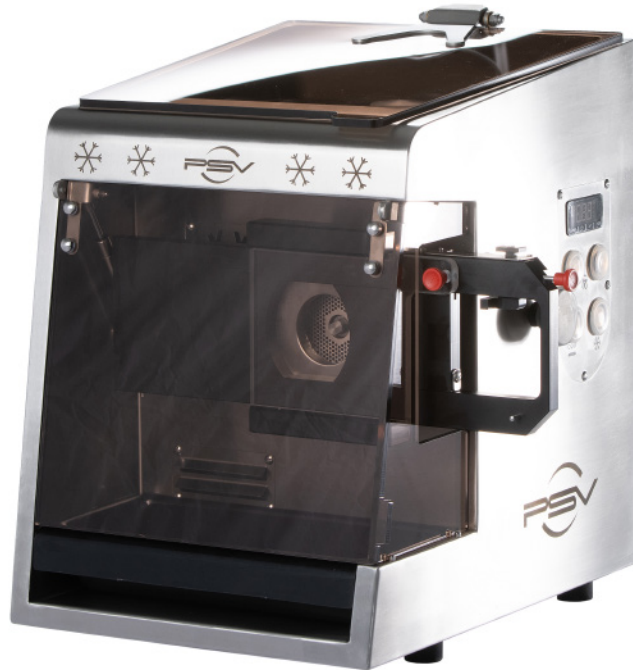

### CARACTÉRISTIQUES

- Hachoir réfrigéré avec vitrine le plus compact du marché
- Plateau entièrement rayonné facilitant le nettoyage des angles
- Vitrine à ouverture verticale permettant d'opérer dans un espace réduit
- Vitrine asservie offrant une sécurité optimale
- Carrosserie monobloc avec une façade lisse
- Panel de commande en acier inoxydable 100% étanche IP67
- Mousse isolante injectée et moulée pour une meilleure isolation thermique

### DOTATIONS DE SERIE

- UNGER 82
- Reconstituteur

### OPTION

- Monophasé

### FEATURES

- Most compact refrigerated mincer with window in the market
- Feeding tray with rounded angles that improves cleaning
- Window with vertical opening that enables operation in a limited space environment
- Motor switch on window offering maximum safety
- Entirely monobloc case with brushed finish
- Command panel 100% stainless steel and watertight IP67
- Injected and molded isolating foam for a better thermal insulation

### STANDARD SET UP

- UNGER 82
- Burger former

### OPTION

- Single phase



Groupe PSV, Usine du Berre au Loup,  
D147-BP20 95420 Genainville-France  
[www.psv-groupe.com](http://www.psv-groupe.com)



fabricant

# HACHOIR RÉFRIGÉRÉ DRC VR82

## REFRIGERATED MINCER DRC VR82

Fiche technique / Technical sheet



### Dimensions en mm

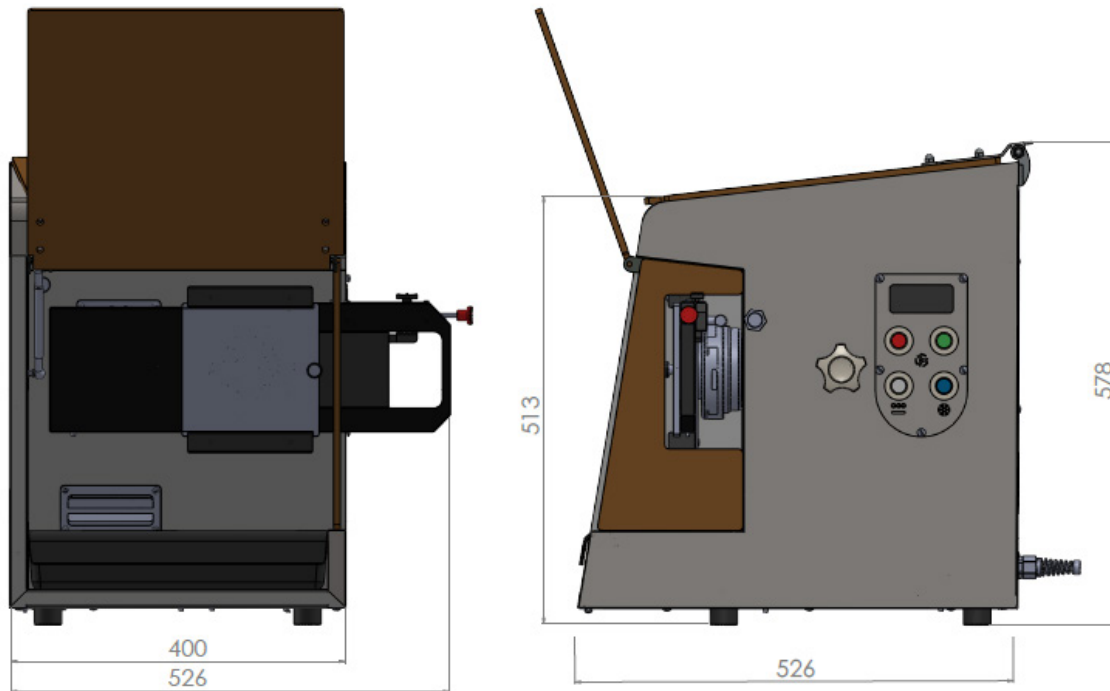

MODÈLE	DIMENSIONS (MM)	COLISAGE (MM)	POIDS (KG)	DÉBIT THÉORIQUE (KG/H)	PUISSANCE MOTEUR	TENSION
MODEL	DIMENSIONS (MM)	PACKING DETAILS (MM)	WEIGHT (KG)	CAPACITY (KG/H)	POWER	VOLTAGE
<b>DRC VR 82</b>	526 x 526 x 578	900 x 720 x 705	60	300	1.5 CH/HP 1.1 kW	3/380V

Disponible en 1/230V

Available in 1/230V



Groupe PSV, Usine du Berre au Loup,  
D147-BP20 95420 Genainville-France  
[www.psv-groupe.com](http://www.psv-groupe.com)