



CARACTÉRISTIQUES

- Deux moteurs distincts
- Deux vitesses de travail indépendantes pour les couteaux et la cuve
- Frein sur arbre moteur
- Nettoyage simple et rapide grâce au design soigné de cette machine
- Machine totalement sécurisée

DOTATION DE SERIE

- Tête 3 couteaux

OPTION

- Tête 6 couteaux
(3 lames + bague de compensation)

FEATURES

- Two distinct motors
- Two independent working speeds for both knives and bowl
- Breaking system on engine shaft
- Simple and fast cleaning thanks to this machine's efficient design
- Fully safe machine

STANDARD SET UP

- Three knives head

OPTION

- Six knives head
(3 blades + compensation ring)

CUTTER VILLA C15

BOWL CHOPPER VILLA C15

Fiche technique / Technical sheet

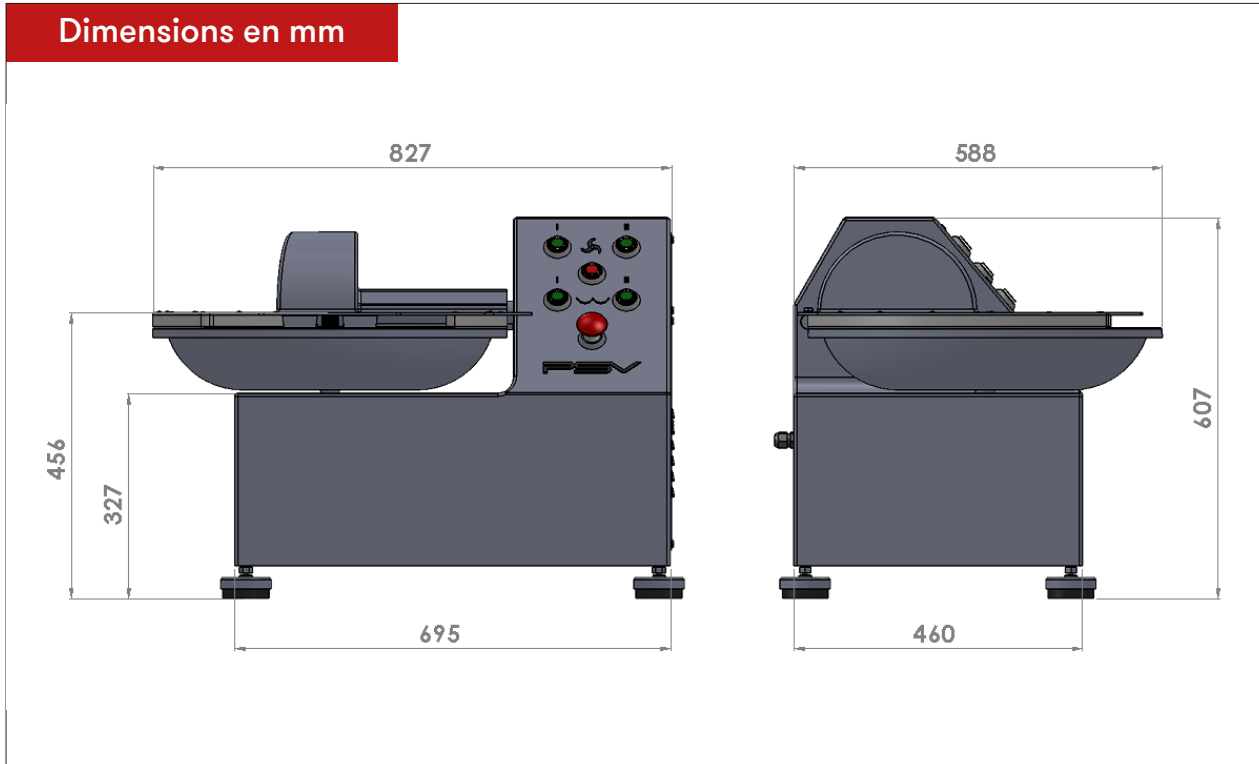

| MODÈLE | ENCOMBREMENT (MM) | COLISAGE (MM) | POIDS (KG) | CAPACITÉ (L) | PUISSANCE MOTEUR DE CUVE ET DE BRAS | VITESSE DE ROTATION CUVE ET COUTEAUX (RPM) | TENSION | QUANTITÉ DE MÉLANGE MAXIMALE (KG) |
|------------|-------------------|----------------------|-------------|--------------|--|--|---------|-----------------------------------|
| MODEL | SIZE (MM) | PACKING-DETAILS (MM) | WEIGHT (KG) | CAPACITY (L) | BOWL MOTOR & KNIVES MOTOR POWER | ROTATION SPEED (RPM) | VOLTAGE | MAXIMUM MIX QUANTITY (KG) |
| C15 | 827 x 588 x 607 | 900 x 720 x 705 | 120 | 15 | Cuve / Bowl : 0.15kW / 0.09kW Couteaux / Knives : 2.2kW / 1.5kW | Cuve / Bowl : 12-24 Couteaux / Knives : 1500 - 3000 | 3/380V | 10 |

