



fabricant

CUTTER VILLA C30

BOWL CHOPPER VILLA C30

Fiche technique / Technical sheet



CARACTÉRISTIQUES

- Deux moteurs distincts
- Deux vitesses de travail indépendantes pour les couteaux et la cuve
- Frein sur arbre moteur
- Nettoyage simple et rapide grâce au design soigné de cette machine
- Machine totalement sécurisée
- Conseil d'entretien : Vérifier régulièrement l'affûtage des couteaux

DOTATION DE SERIE

- Tête 3 couteaux

OPTION

- Tête 6 couteaux
(3 lames + bague de compensation)

FEATURES

- Two distinct motors
- Two independent working speeds for both knives and bowl
- Breaking system on engine shaft
- Simple and fast cleaning thanks to this machine's efficient design
- Fully safe machine
- Maintenance tip : Check regularly for knives proper sharpness

STANDARD SET UP

- Three knives head

OPTION

- Six knives head
(3 blades + compensation ring)



fabricant

Groupe PSV, Usine du Berre au Loup,
D147-BP20 95420 Genainville-France
www.psv-groupe.com



fabricant

CUTTER VILLA C30 BOWL CHOPPER VILLA C30

Fiche technique / Technical sheet

Dimensions en mm

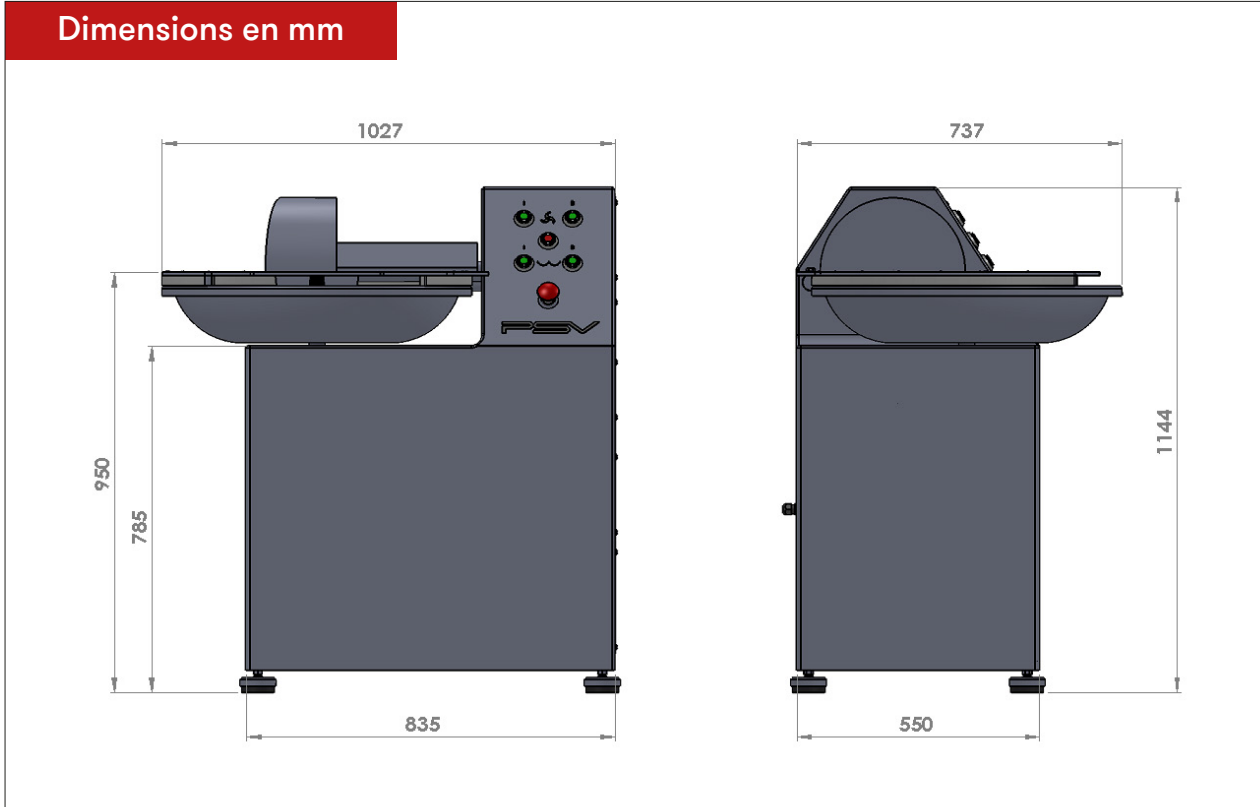

MODÈLE	ENCOMBREMENT (MM)	COLISAGE (MM)	POIDS (KG)	CAPACITÉ (L)	PUISSANCE MOTEUR DE CUVE ET DE BRAS	VITESSE DE ROTATION CUVE ET COUTEAUX (RPM)	TENSION	QUANTITÉ DE MÉLANGE MAXIMALE (KG)
MODEL	SIZE (MM)	PACKING DETAILS (MM)	WEIGHT (KG)	CAPACITY (L)	BOWL MOTOR & KNIVES MOTOR POWER	ROTATION SPEED (RPM)	VOLTAGE	MAXIMUM MIX QUANTITY (KG)
C30	1027 x 737 x 1144	1200 x 800 x 1350	270	30	Cuve / Bowl : 0.3 kW / 0.15 kW Couteaux / Knives : 4.5 kW / 3.4 kW	Cuve / Bowl : 12 - 24 Couteaux / Knives : 1500 - 3000	3/380V	22



Groupe PSV, Usine du Berre au Loup,
D147-BP20 95420 Genainville-France
www.psv-groupe.com