



## CARACTÉRISTIQUES

- Design compact et moderne
- Plateau entièrement rayonné facilitant le nettoyage des angles
- Carrosserie monobloc avec une façade lisse
- Panel de commande en acier inoxydable 100% étanche IP67
- Mousse isolante injectée et moulée pour une meilleure isolation thermique

## DOTATION DE SERIE

- UNGER 98 ou ENTERPRISE 32

## OPTIONS

- Monophasé
- Reconstitueur à steaks

## FEATURES

- Compact and modern design
- Feeding tray with rounded angles that improves cleaning
- Entirely monobloc case with brushed finish
- Panel made of stainless steel and waterproof IP67
- Injected and moulded foam for a better thermal insulation

## STANDARD SET UP

- UNGER 98 ou ENTERPRISE 32

## OPTIONS

- Single phase
- Burger former



fabricant

# HACHOIR RÉFRIGÉRÉ DRC R 32/98 REFRIGERATED MINCER DRC R 32/98

Fiche technique / Technical sheet



## Dimensions en mm

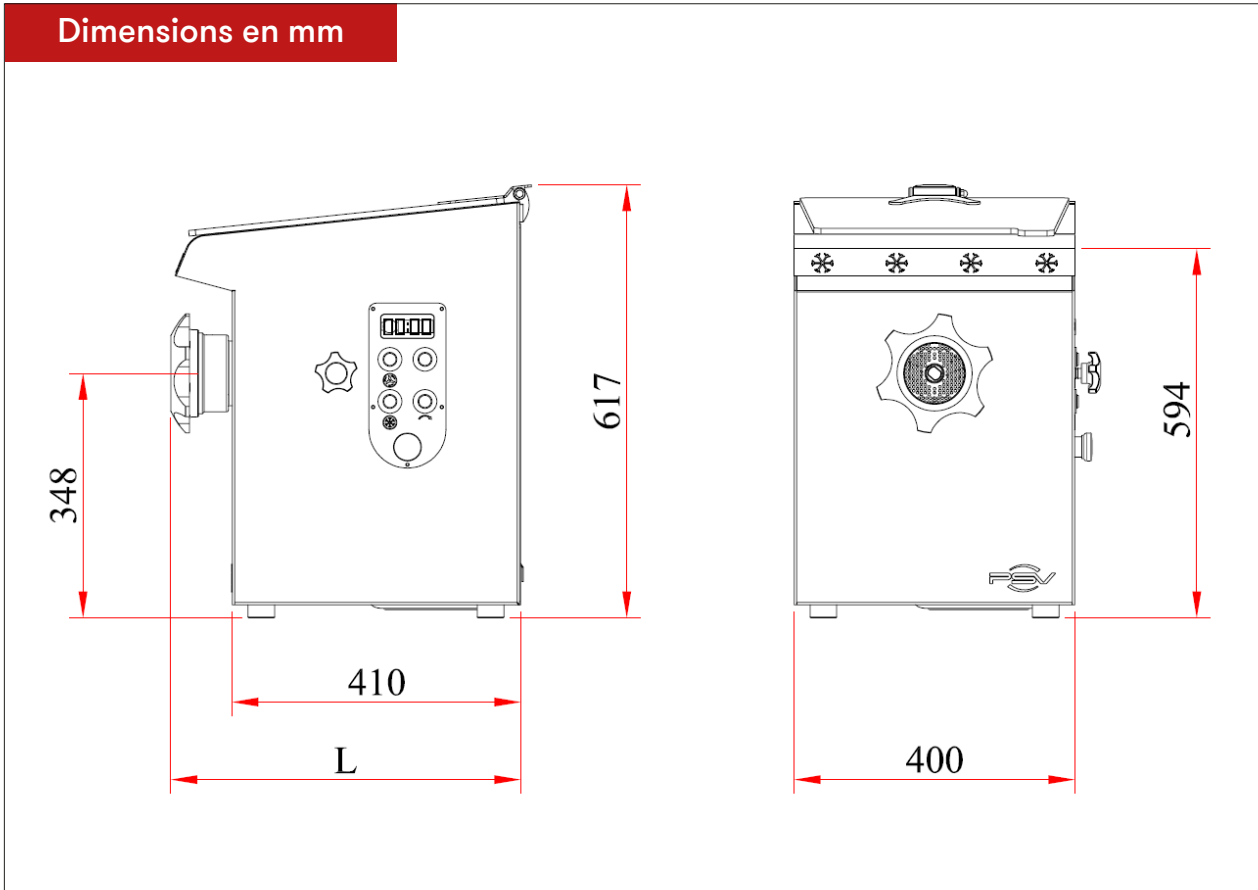

MODÈLE	DIMENSIONS (MM)	COLISAGE (MM)	POIDS (KG)	DÉBIT THÉORIQUE (KG/H)	PUISSANCE MOTEUR	TENSION
MODEL	DIMENSIONS (MM)	PACKING DETAILS (MM)	WEIGHT (KG)	CAPACITY (KG/H)	POWER	VOLTAGE
<b>DRC R 98</b>	535 x 437 x 617	900 x 720 x 705	71	600	3 CH/HP 2.2 kW	3/380V
<b>DRC R 32</b>	510 x 437 x 617					
Disponible en 1/230V						
Available in 1/230V						



Groupe PSV, Usine du Berre au Loup,  
D147-BP20 95420 Genainville-France  
[www.psv-groupe.com](http://www.psv-groupe.com)

fabricant