



fabricant

MÉLANGEUR VILLA M100 MEAT MIXER VILLA M100

Fiche technique / Technical sheet



CARACTÉRISTIQUES

- Entièrement en acier inoxydable
- Cuve motorisée et basculante
- Deux pieds et deux roulettes
- Deux moteurs : Cuve et bras
- Machine totalement sécurisée

OPTIONS

- Bras démontable
- 4 roues pivotantes avec freins et 2 fixes

FEATURES

- Full stainless steel
- Motorized and tiltable bowl
- Two feet and two back wheels
- Two motors : bowl and arm
- Machine fully secure

OPTIONS

- Removable arm
- 4 wheels with brakes and 2 fixed wheels



Groupe PSV, Usine du Berre au Loup,
D147-BP20 95420 Genainville-France
www.psv-groupe.com



fabricant

MÉLANGEUR VILLA M100 MEAT MIXER VILLA M100

Fiche technique / Technical sheet



Dimensions en mm

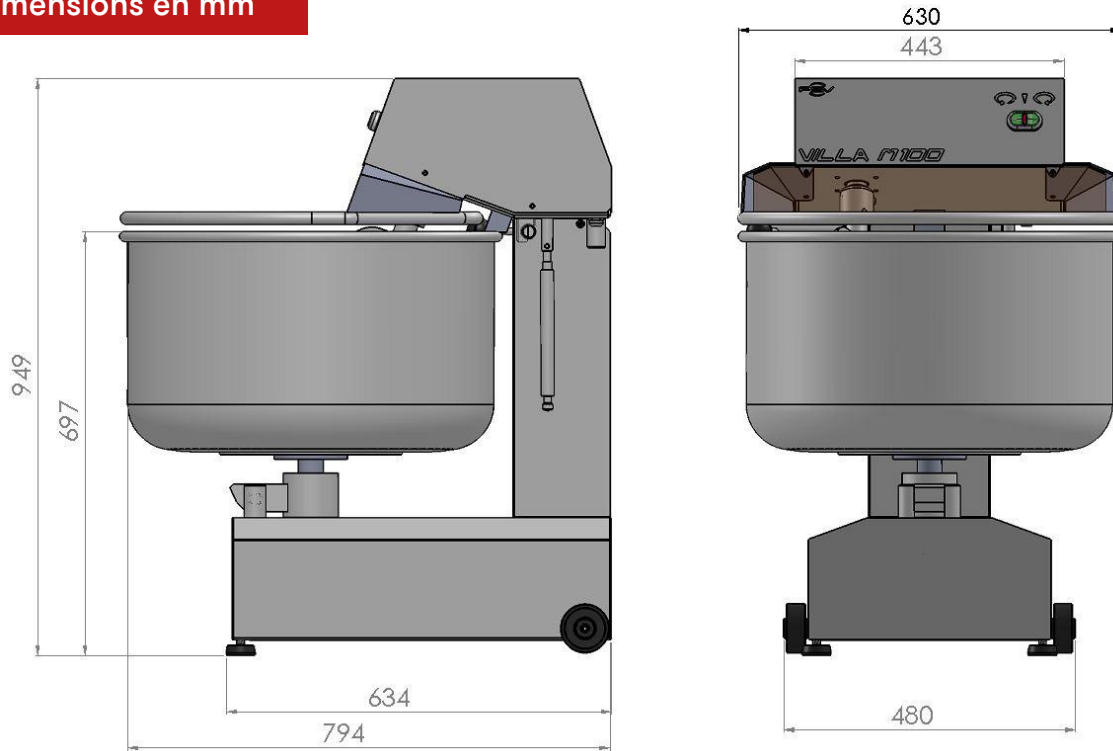

MODÈLE	ENCOMBREMENT (MM)	COLISAGE (MM)	POIDS (KG)	CAPACITÉ (L)	DIMENSIONS DE LA CUVE (MM)	PUISSANCE MOTEUR DE CUVE ET DE BRAS	VITESSE DE ROTATION BRAS ET CUVE (RPM)	TENSION	QUANTITÉ DE MÉLANGE (KG)
MODEL	SIZE (MM)	PACKING DETAILS (MM)	WEIGHT (KG)	CAPACITY (L)	BOWL SIZE (MM)	BOWL MOTOR & KNIVES MOTOR POWER	ROTATION SPEED (RPM)	VOLTAGE	MIX QUANTITY (KG)
M100	794 x 630 x 949	1000 x 850 x 1250	85	100	600 x 360	Bras/Arm : 0.55kW Cuve/Bowl : 0.18kW	Bras/Arm : 47 Cuve/Bowl : 11	3/380V	Mini : 10 Maxi : 55



Groupe PSV, Usine du Berre au Loup,
D147-BP20 95420 Genainville-France
www.psv-groupe.com