



fabricant

MÉLANGEUR VILLA M30 MEAT MIXER VILLA M30

Fiche technique / Technical sheet



CARACTÉRISTIQUES

- Entièrement en acier inoxydable
- Frein manuel sur cuve
- Cuve démontable
- Quatre pieds
- Machine totalement sécurisée

OPTIONS

- Bras démontable
- Moteur mono

FEATURES

- Full stainless steel
- Manual break on bowl
- Removable bowl
- Four feet
- Machine fully secure

OPTIONS

- Removable arm
- Single phase motor



Groupe PSV, Usine du Berre au Loup,
D147-BP20 95420 Genainville-France
www.psv-groupe.com

fabricant



fabricant

MÉLANGEUR VILLA M30

MEAT MIXER VILLA M30

Fiche technique / Technical sheet

Dimensions en mm

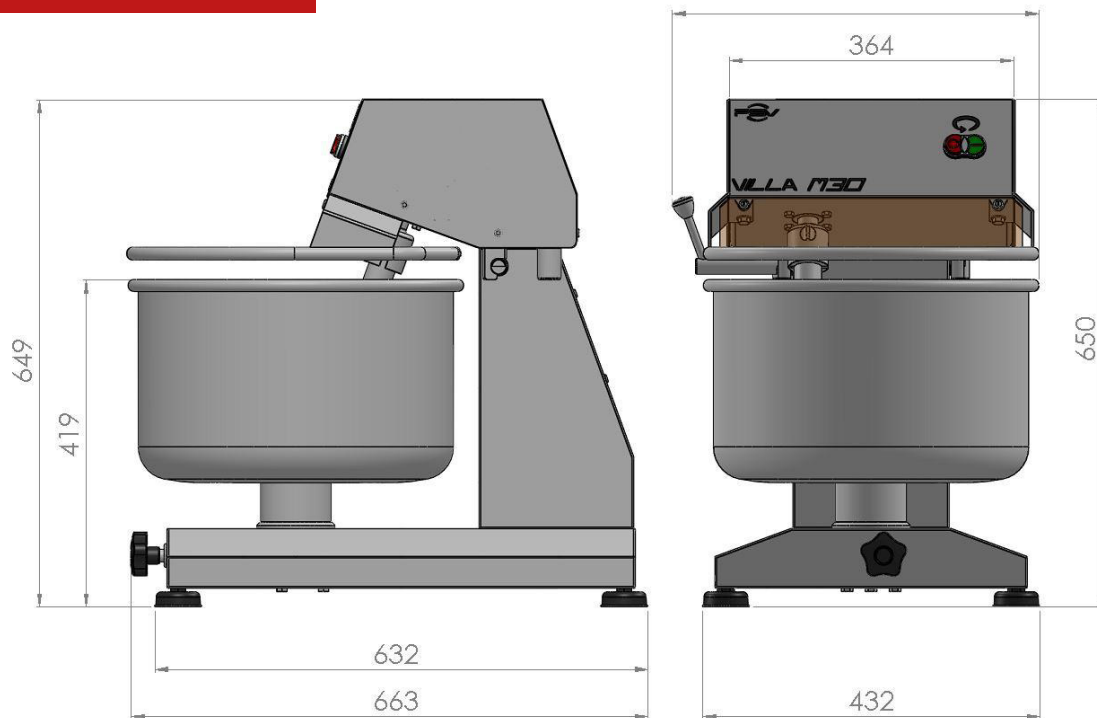

MODÈLE	ENCOMBREMENT (MM)	COLISAGE (MM)	POIDS (KG)	CAPACITÉ (L)	DIMENSIONS DE LA CUVE (MM)	PUISSANCE MOTEUR DE BRAS	VITESSE DE ROTATION BRAS (RPM)	TENSION	QUANTITÉ DE MÉLANGE (KG)
MODEL	SIZE (MM)	PACKING DETAILS (MM)	WEIGHT (KG)	CAPACITY (L)	BOWL SIZE (MM)	KNIVES MOTOR POWER	ROTATION SPEED (RPM)	VOLTAGE	MIX QUANTITY (KG)
M30	470 x 663 x 650	600 x 600 x 800	55	30	400x260	Bras/Arm : 0.18kW	Bras/Arm : 47	3/380V	Mini : 6 Maxi : 15



Groupe PSV, Usine du Berre au Loup,
D147-BP20 95420 Genainville-France
www.psv-groupe.com