



fabricant

MÉLANGEUR VILLA M60 NM MEAT MIXER VILLA M60 NM

Fiche technique / Technical sheet



CARACTÉRISTIQUES

- Entièrement en acier inoxydable
- Cuve basculante
- Deux pieds et deux roulettes
- Machine totalement sécurisée

OPTIONS

- Cuve motorisée
- Bras démontable
- 4 roues pivotantes avec freins et 2 fixes
- Moteur mono

FEATURES

- Full stainless steel
- Tilttable bowl
- Two feet and two back wheels
- Machine fully secure

OPTIONS

- Motorized bowl
- Removable arm
- 4 wheels with brakes and 2 fixed wheels
- Single phase motor



Groupe PSV, Usine du Berre au Loup,
D147-BP20 95420 Genainville-France
www.psv-groupe.com

fabricant



fabricant

MÉLANGEUR VILLA M60 NM MEAT MIXER VILLA M60 NM

Fiche technique / Technical sheet

Dimensions en mm

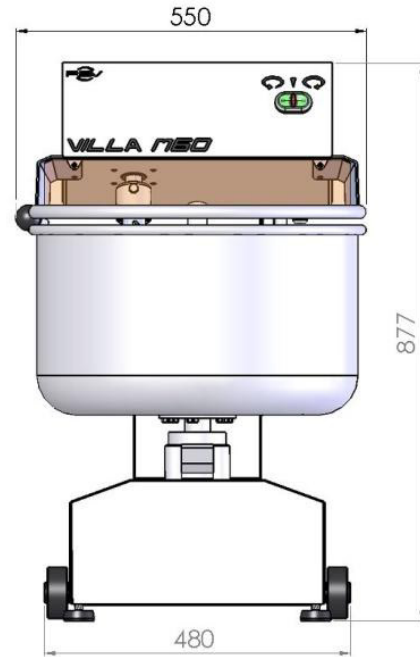
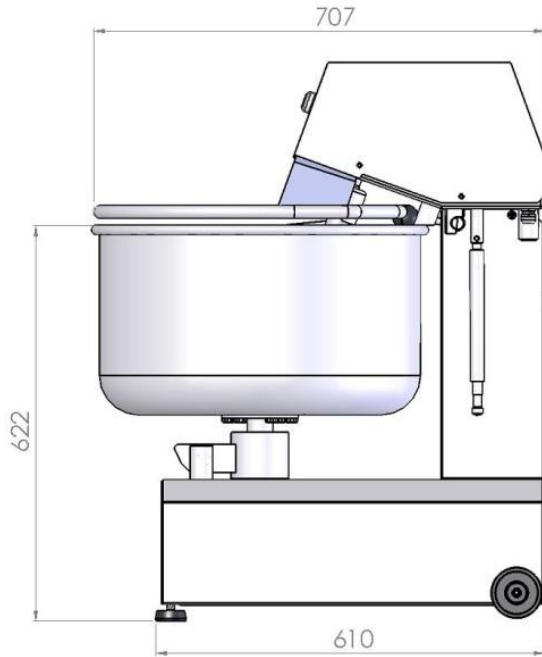

MODÈLE	ENCOMBREMENT (MM)	COLISAGE (MM)	POIDS (KG)	CAPACITÉ (L)	DIMENSIONS DE LA CUVE (MM)	PUISSANCE MOTEUR DE BRAS	VITESSE DE ROTATION BRAS ET CUVE (RPM)	TENSION	QUANTITÉ DE MÉLANGE (KG)
MODEL	SIZE (MM)	PACKING DETAILS (MM)	WEIGHT (KG)	CAPACITY (L)	BOWL SIZE (MM)	ARM MOTOR POWER	ROTATION SPEED (RPM)	VOLTAGE	MIX QUANTITY (KG)
M60 NM	707 x 550 x 877	900 x 720 x 1250	85	60	500 x 300	Bras/Arm : 0.25kW	Bras/Arm : 47	3/380V	Mini : 8 Maxi : 33



Groupe PSV, Usine du Berre au Loup,
D147-BP20 95420 Genainville-France
www.psv-groupe.com