



CARACTÉRISTIQUES

- Entièrement en acier inoxydable
- Design monobloc améliorant l'encombrement et facilitant le nettoyage
- Ouverture frontale offrant un large accès afin de faciliter la maintenance
- Evacuation de l'eau de rinçage directement au sol

DOTATIONS DE SERIE

- 3 cornets en acier inoxydable
- Fonction « start & stop »

OPTIONS

- Socle roulant équipé de 2 roues pivotantes avec freins
- Accessoire à keftas
- Formeuse à steaks
- Dosificateur de 20 à 500 grammes
- Moteur monophasé

FEATURES

- Full stainless steel
- Monobloc design improving room saving and cleaning
- Front opening a wide access that makes maintenance easy and efficient
- Evacuation of rinsing water directly on the floor

STANDARD SET UP

- 3 stainless steel nozzles
- Start & stop feature : motor on and off switch with the knee pedal

OPTIONS

- Rolling base with 2 front drivable wheels with brakes
- Kefta device
- Burger forming device
- Dosing device from 20 to 500 grams
- Single phase motor



fabricant

POUSSOIR HYDRAULIQUE VILLA 40 HYDRAULIC FILLER VILLA 40

Fiche technique / Technical sheet



Dimensions en mm

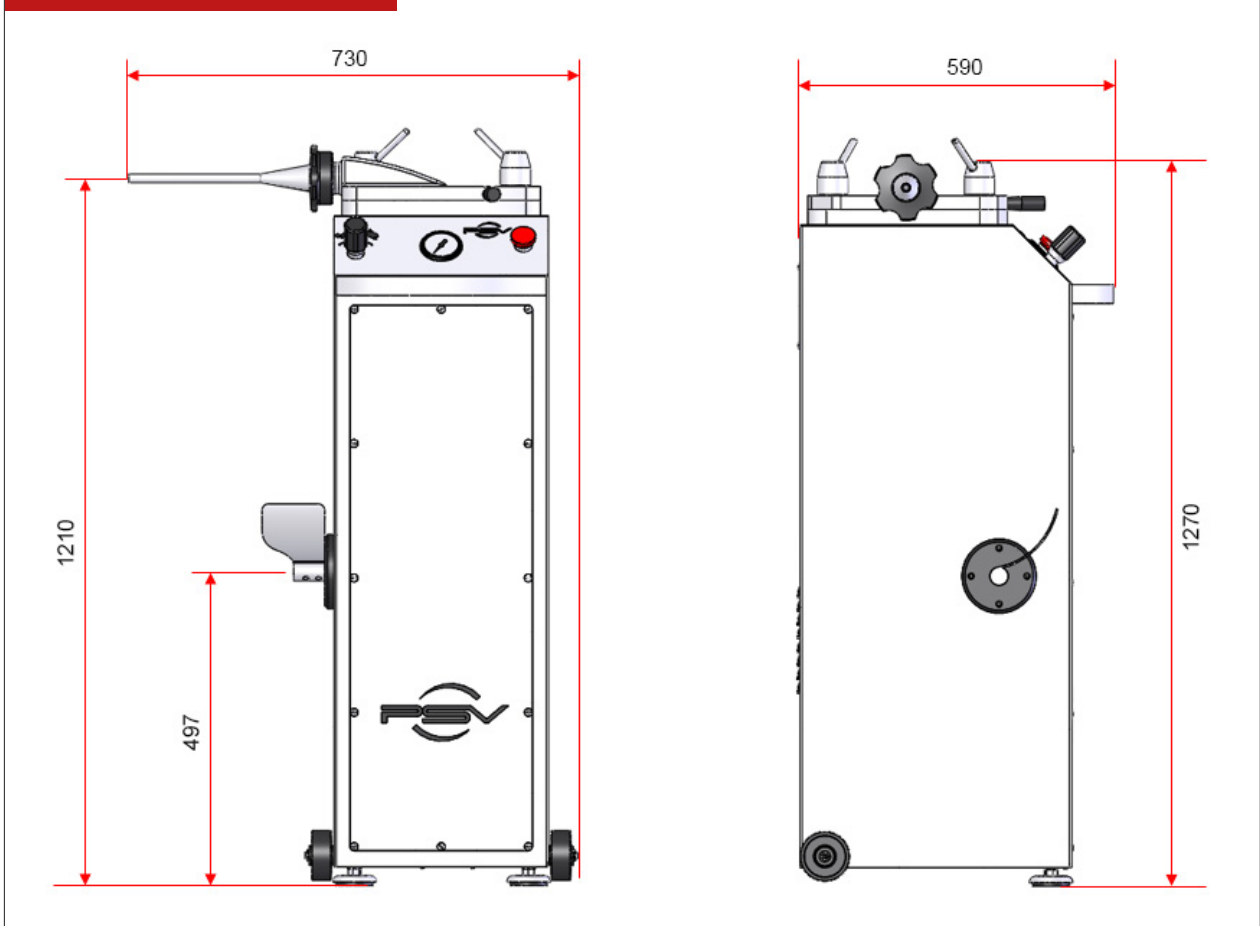

MODÈLE	DIMENSIONS (MM)	COLISAGE (MM)	POIDS (KG)	CAPACITÉ	PUISSANCE MOTEUR	TENSION
MODEL	DIMENSIONS (MM)	PACKING DETAILS (MM)	WEIGHT (KG)	CAPACITY	POWER	VOLTAGE
VILLA40	730 x 590 x 1270	1200 x 800 x 1470	245	40 L 35 kg	1.5 CH/HP 1.1 kW	3/380V



Groupe PSV, Usine du Berre au Loup,
D147-BP20 95420 Genainville-France
www.psv-groupe.com