



fabricant

POUSSOIR MANUEL PV13 MANUAL FILLER PV13

Fiche technique / Technical sheet



CARACTÉRISTIQUES

- Machine 100% inox
- Encombrement réduit
- Cylindre basculant et pivotant entièrement en acier inoxydable
- 2 vitesses d'utilisation possibles

DOTATION DE SERIE

- 3 cornets en aluminium anodisé

OPTION

- Cornets en acier inoxydable

FEATURES

- Full stainless steel machine
- Room saving
- Tilttable cylinder, entirely removable
- 2 available speed

STANDARD SET UP

- 3 anodised aluminium nozzles

OPTION

- Stainless steel nozzles



Groupe PSV, Usine du Berre au Loup,
D147-BP20 95420 Genainville-France
www.psv-groupe.com



fabricant

POUSSOIR MANUEL PV13 MANUAL FILLER PV13

Fiche technique / Technical sheet



Dimensions en mm

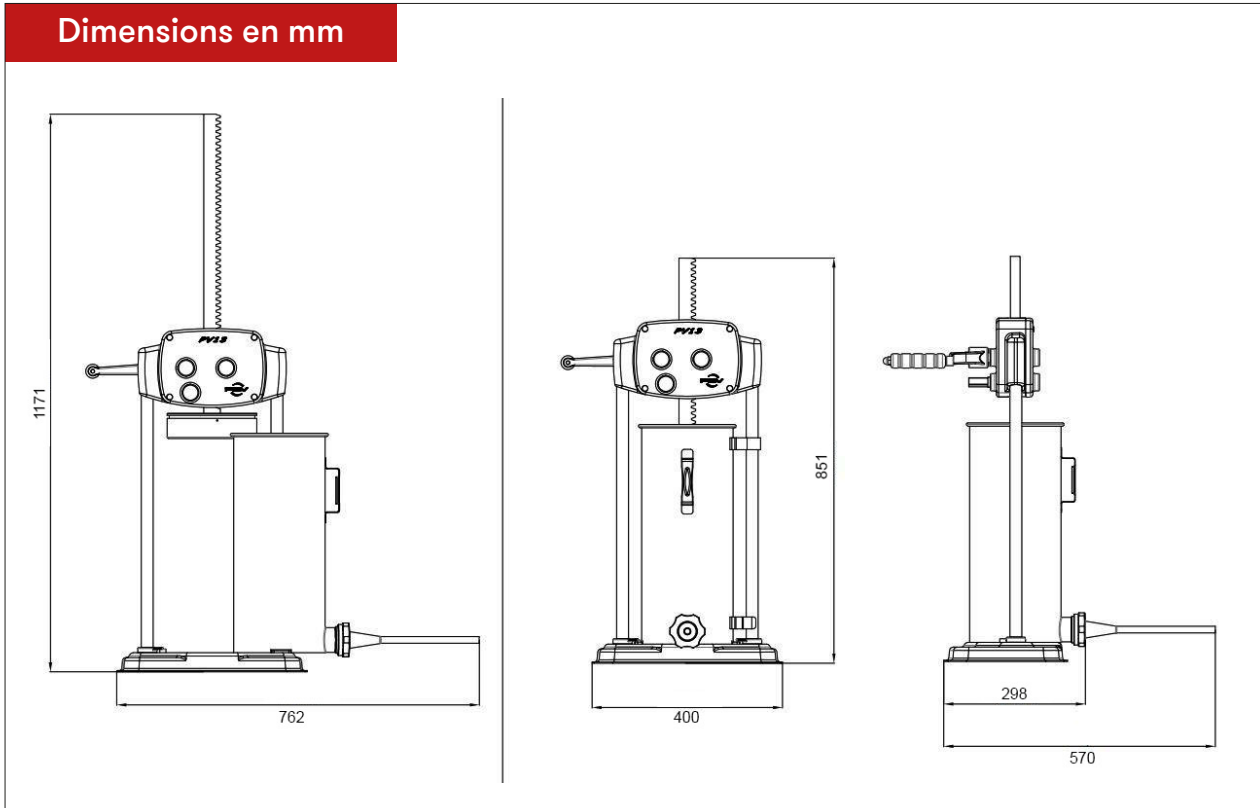

MODÈLE	DIMENSIONS (MM)	COLISAGE (MM)	POIDS (KG)	CAPACITÉ
MODEL	DIMENSIONS (MM)	PACKING DETAILS (MM)	WEIGHT (KG)	CAPACITY
PV13	400 x 570,1 x 850,57	410 x 320 x 900	30	13 L 10-12kg



Groupe PSV, Usine du Berre au Loup,
D147-BP20 95420 Genainville-France
www.psv-groupe.com