



### CARACTÉRISTIQUES

- Carrosserie entièrement en acier inoxydable
- Plateau grand volume
- 4 roues dont 2 directionnelles bloquantes
- Corps démontable rendant le nettoyage très facile
- Marche arrière par impulsion
- Corps extérieur facilitant le travail au-dessus d'un contenant ou de nos mélangeurs M60 et M100

### DOTATION DE SERIE

- UNGER 98 ou ENTERPRISE 32
- Capot de sécurité (moteur asservi)

### OPTION

- Triple coupe ( 5 éléments de coupe ) UNGER 5

### FEATURES

- Case entirely of stainless steel
- High volume tray
- 4 wheels including 2 directional locked
- Dismountable cutting body for an easy cleaning
- Rear motion available with push button
- Outer body designed for ease of work over containers or our M60 and M100 mixers

### STANDARD SET UP

- UNGER 98 ou ENTERPRISE 32
- Safety mouth cover with motor switch

### OPTION

- Triple cut ( 5 cutting elements ) UNGER 5

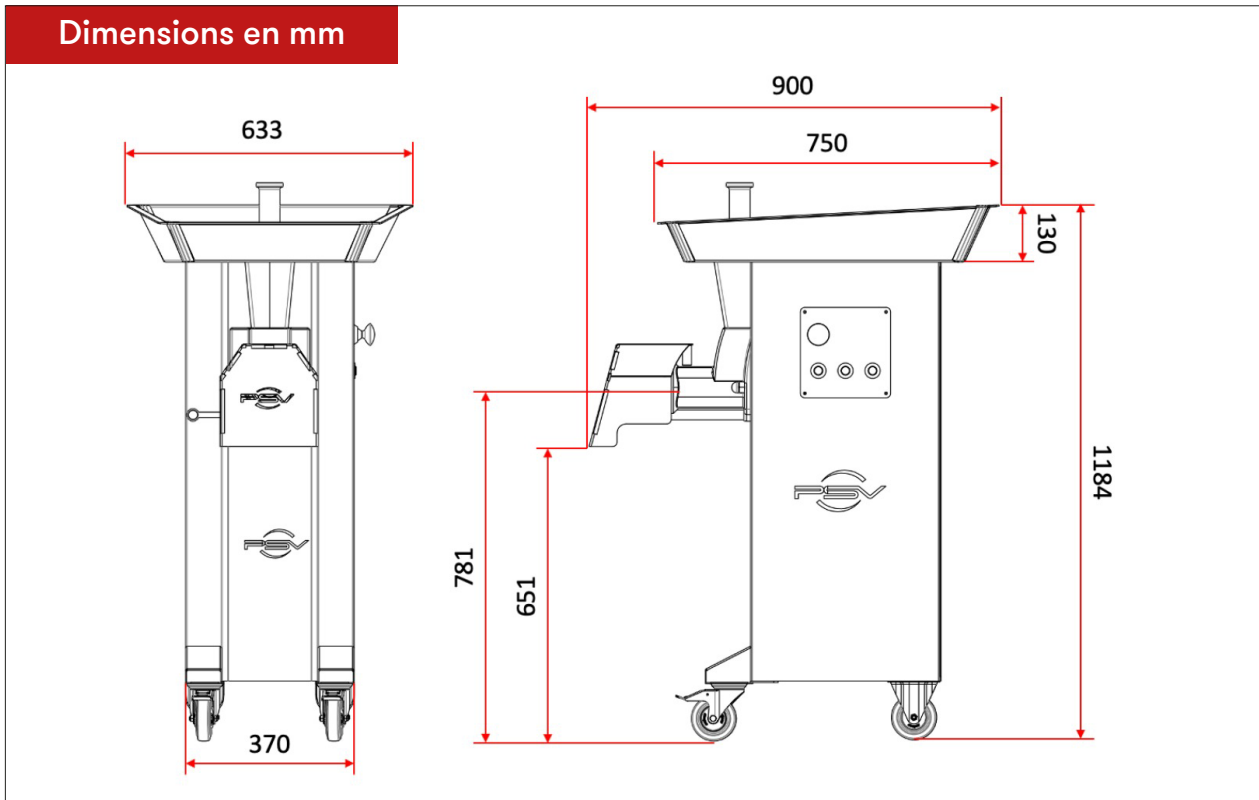

MODÈLE	DIMENSIONS (MM)	COLISAGE (MM)	POIDS (KG)	DÉBIT THÉORIQUE (KG/H)	PUISSANCE MOTEUR	TENSION
MODEL	DIMENSIONS (MM)	PACKING DETAILS (MM)	WEIGHT (KG)	CAPACITY (KH/H)	POWER	VOLTAGE
<b>DRC 98S DRC 32S</b>	1184 x 633 x 900	1370 x 1015 x 1350	100	900	4 CH/HP 3 kW	3/380V