



fabricant

POUSSOIR HYDRAULIQUE VILLA 60

HYDRAULIC FILLER VILLA 60

Fiche technique / Technical sheet



CARACTÉRISTIQUES

- Entièrement en acier inoxydable
- Design monobloc améliorant l'encombrement et facilitant le nettoyage
- Ouverture frontale offrant un large accès afin de faciliter la maintenance
- Evacuation de l'eau de rinçage directement au sol
- Troisième point d'appui au niveau du couvercle pour plus de robustesse
- Machine sur socle roulant avec 4 roulettes (2 fixes et 2 pivotantes)

DOTATIONS DE SERIE

- 3 cornets en acier inoxydable
- Fonction « start & stop »

OPTIONS

- Accessoire à keftas
- Formeuse à steaks
- Dosificateur de 20 à 500 grammes
- Moteur monophasé

FEATURES

- Full stainless steel
- Monobloc design improving room saving and cleaning
- Front opening a wide access that makes maintenance easy and efficient
- Rinse water discharged directly to the floor
- Third support point at the lid for greater strength
- Machine on rolling base with 4 casters (2 fixed and 2 swivel)

STANDARD SET UP

- 3 stainless steel nozzles
- Start & stop feature

OPTIONS

- Kefta device
- Burger forming device
- Dosifier from 20 to 500 grams
- Single-phase motor



Groupe PSV, Usine du Berre au Loup,
D147-BP20 95420 Genainville-France
www.psv-groupe.com



fabricant

POUSSOIR HYDRAULIQUE VILLA 60

HYDRAULIC FILLER VILLA 60

Fiche technique / Technical sheet



Dimensions en mm

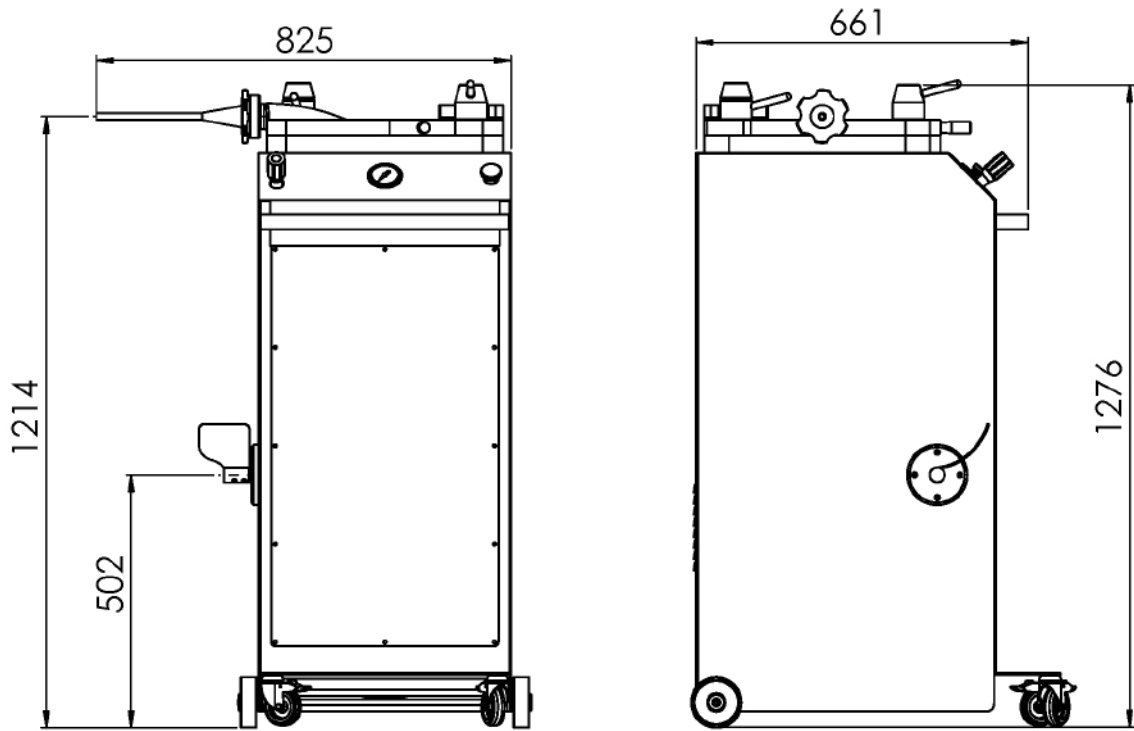

MODÈLE	DIMENSIONS (MM)	COLISAGE (MM)	POIDS (KG)	CAPACITÉ	PUISSANCE MOTEUR	TENSION
MODEL	DIMENSIONS (MM)	PACKING DETAILS (MM)	WEIGHT (KG)	CAPACITY	POWER	VOLTAGE
VILLA 60	825 x 661 x 1276	1200 x 800 x 1470	260	60 L 55 Kg	1.5 CH/HP 1.1 kW	3/380



Groupe PSV, Usine du Berre au Loup,
D147-BP20 95420 Genainville-France
www.psv-groupe.com